



INFLIGHT FITNESS



LIBERATOR

MULTI-STACK FITNESS SYSTEM



The Liberator by Inflight Fitness is the most compact, versatile, and durable commercial strength training system on the market today.

Modern styling and rugged dependability are combined in a compact package that is destined to meet your budget and exceed any workout enthusiast's expectations.

The Liberator Strength Training system allows three users to workout simultaneously and four users when you add the optional fourth weight stack. Simplicity and reliability in design are hallmarks of the Liberator Strength Training System, with minimal adjustments to manage and the heaviest duty commercial components for reliability.

The Liberator Strength Training System IS the strength training system you have been searching for!!!



Shown with optional shrouds

THE Ultimate three or four weight stack Strength Training System for your gym or fitness center!



Optional 4th Stack Leg Press



Optional 4th Stack Cable Column



Standard Liberator Configuration



Commercial rated 1" shafts and pillow block bearings assure precise movement while providing ultimate durability.



Each exercise station features easy to understand instructional placards to demonstrate machine set-up, proper form, and targeted muscle groups.



Premium upholstered padding is full commercial, 40-50 durometer HR foam with sewn vinyl covers for maximum strength and a tailored look. Contoured seat and back pads provide lumbar support and maximum comfort.



The open yoke Lat Pulldown has wide-open head clearance for safety. Also, the Shoulder Press allows for presses to be performed seated upright, facing in or out, for greater joint comfort.



Our cables are twice as strong as most competitors' cables. We use Loos USA 4000lb rated military-spec cables with stainless steel swaged ball ends for maximum life expectancy and user safety. The cables are routed over extra large 4 1/2" and 6" pulleys.



All Hand Grips are made of non-absorbent UV resistant, closed cell foam and are finished with machined aluminum grip caps to prevent wear while looking great. Hand Grips are positioned to keep joints in a neutral position, reducing joint stress and maximizing a safe workout experience.



Each station boasts a 200lb. tiered weight stack. Additional weight can be ordered in 50lb. increments up to 300lb per station! Steel weight stack selector pins are attached by a coiled lanyard to help prevent loss.



The Liberator Strength Training System allows the user to position the seats for their height and comfort with our easy to use ratchet adjustment system.

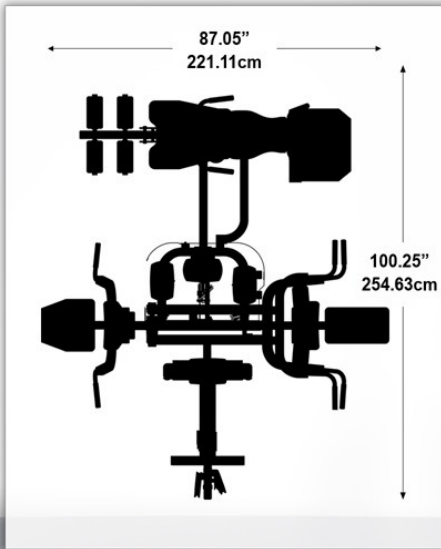

With Optional 4th Stack Cable Column

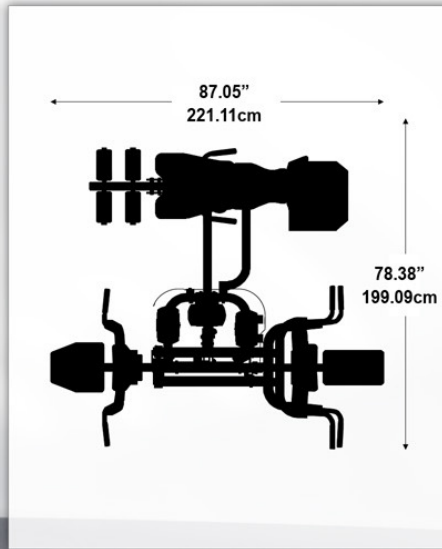

Standard 3 Stack Configuration

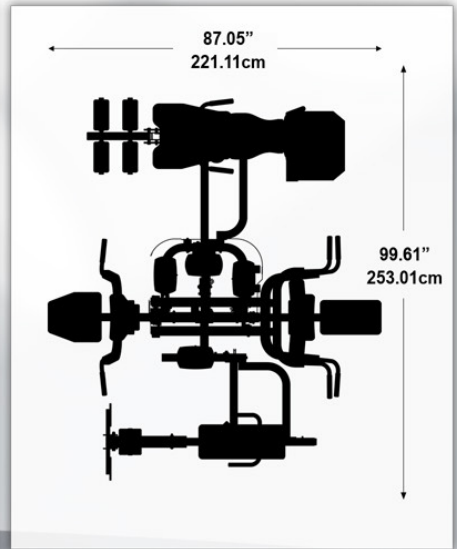

With Optional 4th Stack Leg Press

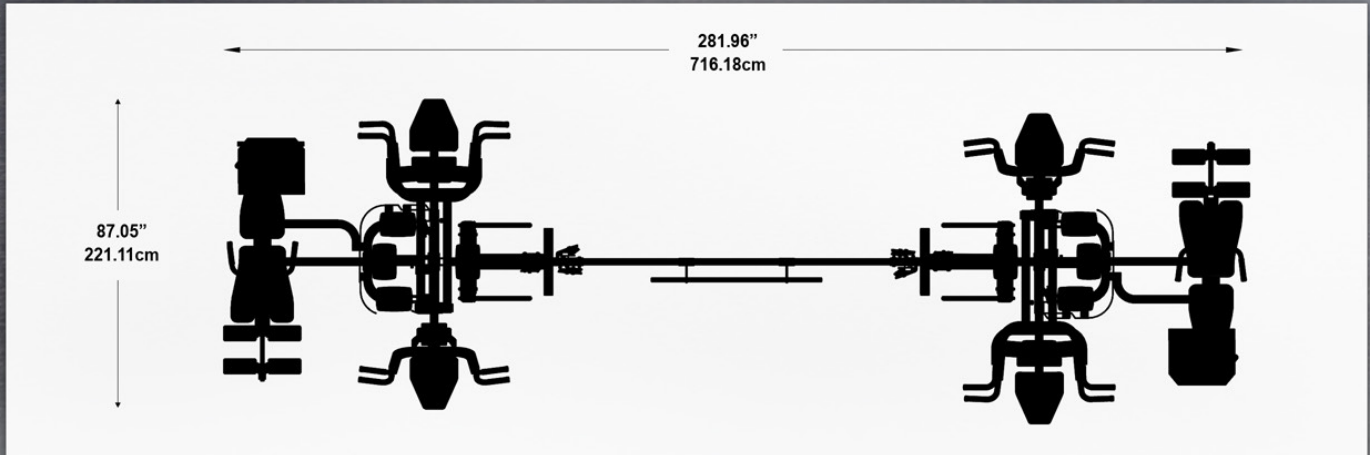

8 Stack Multi-Gym Configuration

EXERCISE STATIONS

STATION 1:	Lat Pull, Shoulder Press
STATION 2:	Seated Leg Extension, Lying Leg Curl, Bicep Curl, Low Row
STATION 3:	Chest Press, Ab Crunch, Overhead Triceps
STATION 4:	Leg Press OR Cable Column
8 STACK:	Standard Stations 1-3 Plus Cable Column (x2)

All Inflight Fitness Machines have a lifetime warranty on the frame and welds and one year on cables, pulleys and moving parts. Additional terms and conditions apply. See warranty for details. Inflight Fitness reserves the right to make design changes at any time.



8321 STANDUSTRIAL STREET - STANTON, CA 90680 - TEL. 714 821 4177 - FAX. 714 821 4181
www.inflightfitness.com

See more at www.inflightfitness.com or on Facebook at Inflight Fitness Products